

CycloBlower T5

Blower



Features:

- Operating overpressure up to 1.4 bar
- Volume flow: 400 – 1200 m³/h
- Clockwise and counter-clockwise rotation
- Universal shaft or V-belt drive
- Speed range: 1000 – 2000 1/min
- Low maintenance

Applications:

- For the pneumatic handling of cereal grains and fodder up to 1.2 bar

Technical data:

T5 CDL 9	Volume flow m ³ /h /		Power requirement kW	
	0,8 bar	1,0 bar	1,2 bar	1,4 bar
Speed				
1000	374 / 14	360 / 16	340* / 18	- / -
1250	522 / 17	505 / 21	485 / 24	459* / 27
1500	672 / 21	655 / 23	638 / 26	605* / 32
1750	819 / 24	805 / 28	785 / 31	755* / 38
2000	969 / 28	955 / 32	935 / 36	910* / 45

T5 CDL 12	Volume flow m ³ /h /		Power requirement kW	
	0,8 bar	1,0 bar	1,2 bar	1,4 bar
Speed				
1000	510 / 18	490 / 20	468 / 22	- / -
1250	697 / 22	680 / 25	655 / 29	604* / 35
1500	893 / 28	875 / 31	850 / 35	799* / 43
1750	1088 / 32	1065 / 37	1037 / 42	986* / 51
2000	1275 / 37	1260 / 43	1233 / 49	1182* / 60

The design concept of the blower series T5 is unique. Helical intermeshing rotors running contact-free eliminate the need for valves and other parts that are subject to wear and tear. The dynamically balanced rotors guarantee low noise and dependable operation.

* only for intermitted operation

CycloBlower T5

Blower

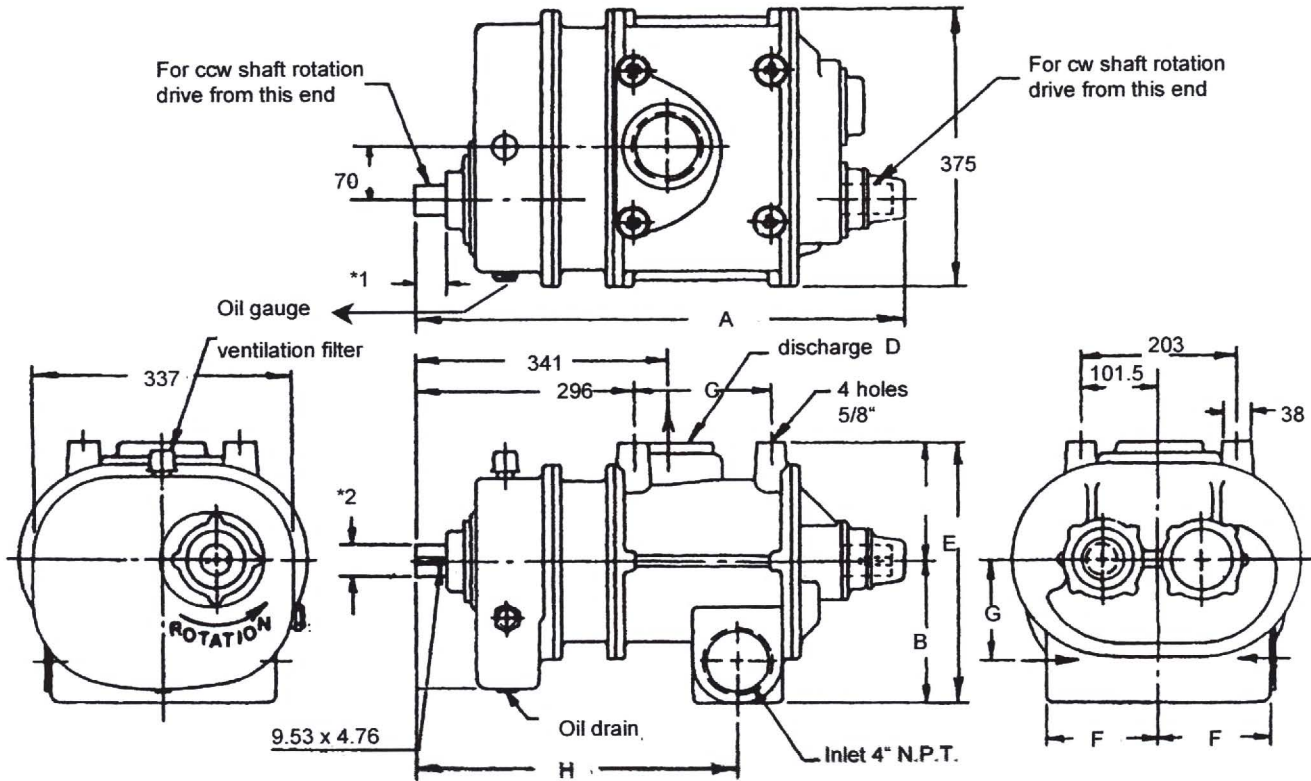

	A	B	C	D	E	F	G	H
T5 CDL 9L	660	191	178	3" N.P.T.	350	146	134	430
T5 CDL 12L	735	216	254	4"N.P.T.	375	152	146	492

Construction	L	L72
*1	55	65
*2	41.28	38.10
	41.25	38.07

all dimensions in mm